



# MOTORTRONICS™

Solid State AC Motor Control

# VMX2

VMX2 SERIES COMPACT SOFT STARTER

## BASIC INSTALLATION AND STARTUP GUIDE

208 - 600V, 9 - 1250 Amps, 5 - 1200 HP



## Table of Contents

<b>Quick Start “Minimum Settings” Guide .....</b>	<b>4</b>
<b>Chapter 1: Introduction .....</b>	<b>5</b>
General Description, Sizes and Ratings .....	5
Dimensions and Weights .....	6
<b>Chapter 2: Installation .....</b>	<b>8</b>
Receiving, Unpacking and Inspection .....	8
SERVICE WARNING!.....	8
Mounting Clearances and Cleaning .....	8
Electrical Connections .....	9
Power Connections .....	9
Bypass Contactor .....	9
Power Factor Correction Capacitors .....	9
Power Terminals .....	10
Remote Keypad Mounting .....	10
Control Connections .....	11
AC Control Power Supply Connection .....	12
Control Fusing .....	12
Three-Wire Control Connection .....	13
Seal In Contact.....	13
Two Wire Control: Relay / PLC Connection .....	13
Interlock Connection.....	13
Dual Ramp and Jog Features .....	14
Analog Output (4-20mA).....	15
External Overload Relay Connection .....	15
Fault Signal .....	16
Output (Auxiliary) Relay Contacts.....	16
Bypass Contactor Control.....	17
<b>Chapter 3: Sequence of Operation .....</b>	<b>19</b>
Starting and Stopping .....	19

### Table of Contents - Continued

<b>Chapter 4: Programming</b> .....	20
Introduction .....	20
Digital Interface .....	21
Display and Program Modes .....	21
Program Function List .....	24
Auxiliary Output Relay Settings .....	31
Fault Mode .....	32
<b>Chapter 5: Motor Overload Protection</b> .....	33
Solid State Overload Protection .....	33
Manual Reset .....	34
Automatic Reset .....	34
Overload Class Trip Curves .....	35

**California Customers:**

**California Proposition 65 Warning**

WARNING: this product and associated accessories may contain chemicals known to the State of California to cause cancer, birth defects, or other reproductive harm. For more information visit <https://p65warnings.ca.gov>

## Quick Startup “Minimum Settings” Guide

Your new **VMX2 Series** Soft Starter is factory preset for a wide variety of applications and often can be used with minimal adjustment.

**Try these initial factory presets first** and then adjust or enable the more advanced features to meet your specific starting needs.

### Three Step Process:

1. **Connect L1, L2, L3 to power lines and T1, T2, T3 to motor (see page 9)**
2. **Connect control wires and control power (see pages 11-16)**
3. **Program motor FLA (see page 23).**

### Your VMX2 unit is ready to start!

#### Start-up Check List



- Supply voltage matches the rated supply voltage of the unit.
- Horsepower and current ratings of the motor and unit match or the unit is higher rating.
- Initial ramp time and torque adjustments have been checked.
- Power lines are attached to the unit input terminals marked L1, L2 and L3 (R, S, T).
- Motor leads are connected to the lower terminals marked T1, T2, and T3 (U, V, W).
- Appropriate control power is applied
- Control connections have been made.
- “Power on” light located on the front of the unit turns on when control power is applied.
- Four seven-segment LED readouts are visible.
- The motor’s FLA has been programmed in function F001.
- The thermal overload is properly set. (Use F003 and F004 to set OL Class.)
- The motor area and equipment are clear of people and parts before start-up.

**This list provides only the bare minimum settings necessary to make your motor run, and provides basic levels of motor protection. Safety precautions, listed further on in this manual, must always be followed. Ramp setting adjustments and additional protection features may be necessary. Please read further for additional details.**

## Chapter 1 - Introduction

### General Description

The **VMX2 Series** is a digitally programmable solid-state reduced voltage soft starter. Its six SCR design features a voltage/current ramp with an anti-oscillation circuit for smooth load acceleration. The SCRs are sized to withstand starting currents of 500% for 20 seconds (Standard Duty) and up to 500% for 60 seconds (Heavy Duty). The **VMX2 Series** features smooth, stepless ramp control, which reduces motor inrush current and excessive wear on the mechanical drive train components. The **VMX2 Series** includes a programming keypad for setting operating parameters for the ideal starting cycle and protection features, plus easy to understand diagnostic LEDs.

Starting torque, ramp time, current limit, dual ramp, and Decel control are standard features on the **VMX2 Series**. By simply adjusting the units' starting torque, ramp time, and current limit functions, the starting electrical characteristics of the motor can be matched to the mechanical characteristics of the drive train for controlled acceleration of the load. The **VMX2 Series** includes solid-state electronic overload protection in addition to numerous other protective features. It requires 120VAC (220VAC optional) control power and uses dry contact inputs for Start / Stop control. Programmable auxiliary contacts and provisions for interlocking are also included.

### Sizes and ratings

Model Number	Current Range
	Min. - Max.
VMX2-18-BP	9 - 18
VMX2-28-BP	14 - 28
VMX2-39-BP	19 - 39
VMX2-48-BP	24 - 48
VMX2-62-BP	36 - 62
VMX2-78-BP	39 - 78
VMX2-92-BP	46 - 92
VMX2-112-BP	56 - 112
VMX2-150-BP	75 - 150
VMX2-160-BP	80 - 160
VMX2-210-BP	105 - 210
VMX2-275-BP	137 - 275
VMX2-361-BP	180 - 361
VMX2-450-BP	225 - 450
VMX2-550-BP	275 - 550
VMX2-600-BP	300 - 600
VMX2-862-BP	431 - 862
VMX2-900-BP	450 - 900
VMX2-1006-BP	503 - 1006
VMX2-1250-BP	625 - 1250

The Motortronics **VMX2 Series** starters are **current rated** controllers. Max. Amp ratings are for continuous duty and must not be exceeded. Always check the motor nameplate FLA and Service Factor (if used) to ensure proper sizing. Each size has an adjustable range of current from 50% to 100% of the Max Amp rating. Table 1 to the left shows the Current Ratings available.

Table 1: VMX2 Series selection

### Dimensions and Weights

Enclosure	Model Number	Overall			Mounting			Weight lbs (kg)
		A Inches (mm)	B Inches (mm)	C Inches (mm)	D Inches (mm)	E Inches (mm)	F Inches (mm)	
Panel (open) with integral bypass contactor	VMX2-18-BP through VMX2-48-BP	8.85 (230)	8.00 (203)	6.65 (169.7)	8.06 (204.7)	7.00 (177.8)	0.22 (5.6)	13 (5.9)
	VMX2-62-BP through VMX2-112-BP	14.00 (355.6)	8.00 (203)	6.65 (169.7)	13.25 (336.6)	6.75 (171.5)	0.28 (7.1)	23 (10.4)
	VMX2-150-BP and VMX2-160-BP	19.00 (487.9)	8.00 (203)	6.65 (169.7)	18.25 (463.6)	6.75 (171.5)	0.28 (7.1)	35 (15.9)
	VMX2 -210-BP and VMX2-275-BP	28.10 (723.9)	12.5 (317.5)	9.1 (229.4)	27.38 (695.5)	10.75 (273.1)	0.40 (10.2)	90 (40.9)
	VMX2-361-BP and VMX2-450-BP	29.30 (744)	12.5 (317.5)	9.1 (229.4)	27.38 (695.5)	10.75 (273.1)	0.40 (10.2)	105 (47.7)
	VMX2-550-BP through VMX2 -600-BP	329.50 (786.9)	12.5 (317.5)	9.1 (229.9)	27.38 (695.5)	10.75 (273.1)	0.40 (10.2)	120 (55)
	VMX2-862-BP through VMX2-900-BP	44.25 (1124)	25.5 (647.7)	11.86 (301.3)	43.00 (1092.2)	23.00 (584.2)	0.40 (10.2)	Contact Factory
	VMX2-1006-BP through VMX2 -1250-BP	50.77 (1182.6)	25.5 (718.3)	13.28 (332.7)	42.75 (1095.9)	23.24 (590.3)	0.40 (10.2)	Contact Factory

Table 2: VMX2 Dimensions (subject to change)

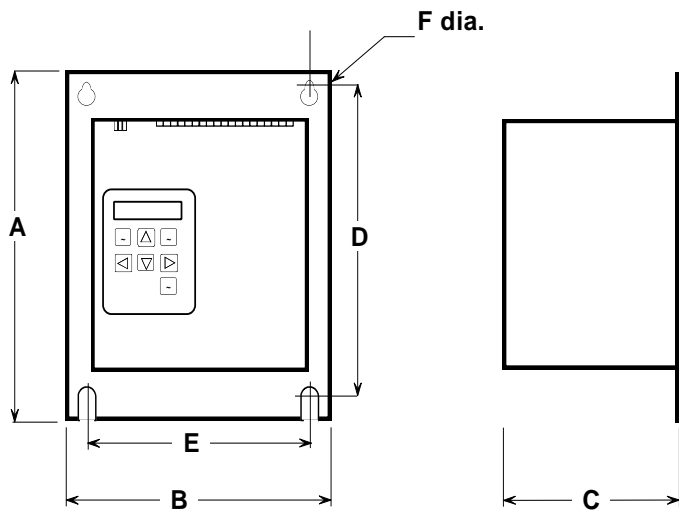

Figure 1: VMX2 Dimensions

## Chapter 2 – Installation

### Receiving and Unpacking

Upon receipt of the product, you should immediately do the following:

- Carefully unpack the unit from the shipping carton and inspect it for shipping damage. *If damaged, notify the freight carrier and file a claim within 15 days of receipt.*
- Verify that the model number on the unit matches your purchase order.
- Confirm that the ratings nameplate on the unit match or are greater than the motors' HP and current rating with which it is to be used.

### Choosing a Location

Proper location of the **VMX2 Series** is necessary to achieve specified performance and normal operation lifetime.

The **VMX2 Series** should always be installed in an area where the following conditions exist:

Ambient operating temperature:

- Panel (open chassis) unit: 0 to 50°C (32 to 122°F)
- Enclosed unit: 0 to 40°C (32 to 104°F)
- Protected from rain, moisture and dust.
- Enclosed units should not be exposed to direct sun.
- Humidity: 5 to 95% non-condensing
- Free from metallic particles, conductive dust and corrosive gas
- Free from excessive vibration (below 0.5G)

**Open panel units must be mounted in the appropriate type of enclosure.** Enclosure size and type must be suitable to dissipate heat generated by the soft starter and any other components mounted inside with it.

**Units with –BP Bypass Contactors** produce less heat than units without. Throughout all sizes, maximum heat dissipation of the VMX2...-BP Series electronics, contactor coils and fans is less than 50W.

**NOTE: This does not include heat generated by cables, lugs or busbars.**

### Initial Unit Inspection

Make a complete visual check of the unit for damage that may have occurred during shipping and handling. Do not attempt to continue installation or start up the unit if it is damaged.

Check for loose mechanical assemblies or broken wires which may have occurred during transportation or handling. Loose electrical connections will increase resistance and cause the unit to function improperly.

### Mounting and Cleaning

When drilling or punching holes in the enclosure, cover the electrical assembly to prevent metal filings from becoming lodged in areas which can cause clearance reduction or actual electrical shorts. After work is complete, thoroughly clean, vacuum the area, and re-inspect the unit for foreign material.



### SERVICE WARNING!

**Do not service equipment with voltage applied! The unit can be the source of fatal electrical shocks! To avoid shock hazard, disconnect main power and control power before working on the unit. Warning labels must be attached to terminals, enclosure and control panel to meet local codes. Use Lock Out tags such as the one shown when servicing equipment.**

### Clearances

Make sure there is sufficient clearance all around the unit for cooling, wiring, and maintenance purposes. To conserve panel space, the **VMX2 Series - BP** models were designed for close clearances of only 1 inch (25mm) on either side. A minimum clearance of 4 inches (100 mm) on the top and bottom is necessary to maximize effective airflow and cooling. Also the unit must be installed with its heat sink ribs oriented vertically and running parallel to the mounting surface. Keep in mind that these are minimums. NEC or local codes may require more clearance, particularly for the power terminals.

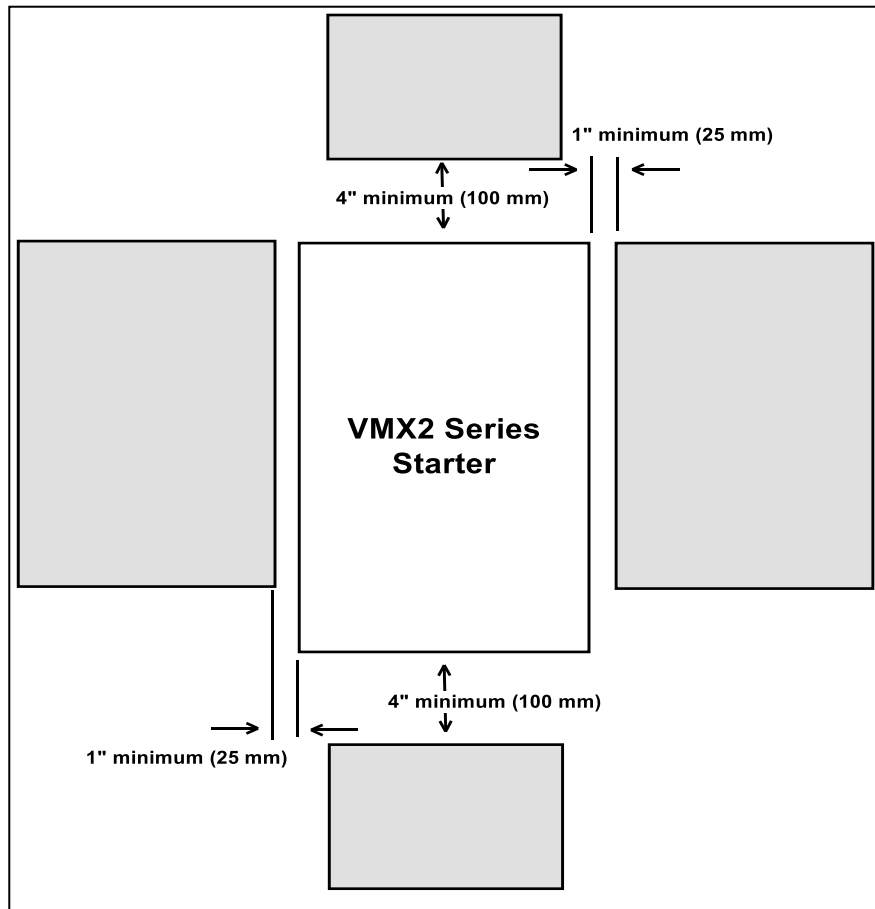

Figure 2: VMX2 minimum mounting clearances

### Cleaning:



**WARNING!**  
Remove all sources of power before cleaning the unit.

In dirty or contaminated atmospheres, the unit should be cleaned on a regular basis to ensure proper cooling. Do not use any chemicals to clean the unit. To remove surface dust use clean, dry compressed air only, 80 to 100 psi. A three inch, high quality, dry paintbrush is helpful to loosen up the dust prior to using compressed air on the unit. Do not use wire brushes or other conductive cleaning materials.



**Electrical Connections**

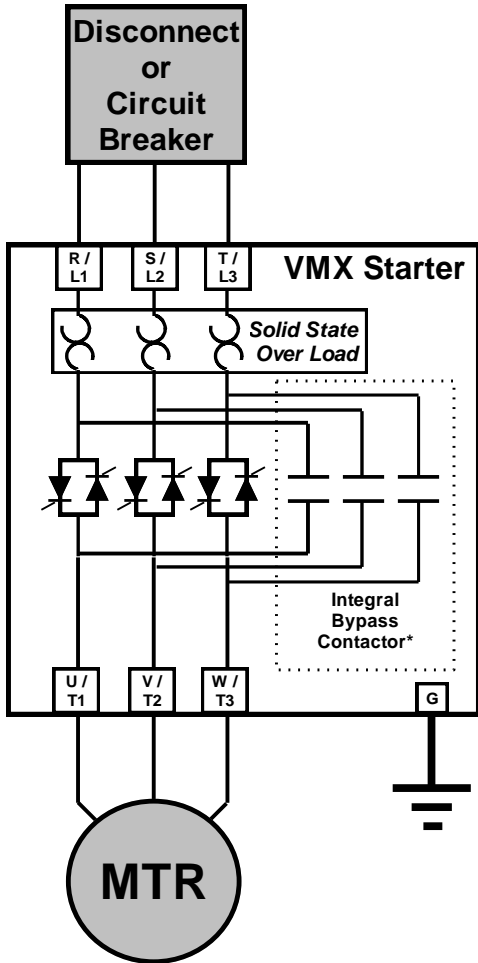

**Figure 3:**  
**VMX2 Power Connections**

**Power Connections**

Referring to local code standards for wire sizing and length, connect power conductors to the unit input terminals marked L1, L2, L3 (R, S, T for IEC users). Connection points are bus tabs with pre-drilled holes (see section 2 of the Advanced Installation, Operation and Programming Manual). Use appropriate compression or mechanical lugs for termination to these bus tabs. Avoid routing power wires over the control board or display. Connect the motor leads to the unit terminals marked T1, T2, T3 (U, V, W for IEC users). If control power is present, but line power is disconnected from L1, L2, L3, the display will show [n3PH] indicating “no 3 Phase”.

**Caution!**



**Never interchange input and output connections to the unit. This could cause excessive voltage in the control logic circuit and may damage the unit.**

**Bypass Contactor**

Bypass Contactors are integral (built-in) on all VMX2 versions. See sections 1.2.3, 3.1.3.c and Appendix 4 of the Advanced Installation, Operation and Programming Manual for more details on contactor control and overload protection details.

**Power Factor Correction Capacitors**

Power factor correction capacitors can be connected to motors controlled by **VMX2 Series** starters, however they must be off-line during ramping. Connect PFC capacitors to the Line side of the starter with a separate capacitor control contactor.



**WARNING!**

**Never connect power factor correction capacitors on the load side of the unit. The SCRs will be seriously damaged if capacitors are located on the load side.**

**Grounding**

Connect the ground cable to the ground terminal as labeled on the unit. Refer to the National Electrical Code or your local Code for the proper ground wire sizing and be sure that the ground connector is connected to earth ground. In ungrounded systems, it is not necessary to connect a ground to the unit however local codes should always be consulted.

**Power Terminals:**

Connection points are bus tabs with pre-drilled holes (see below). Use appropriate compression or mechanical lugs for termination to these bus tabs.

Suggested wire sizes and tightening torques for factory-supplied connectors for conductors rated for 75°C are shown in the chart below. Always consult local codes and industry standard practices for proper wires sizes to accommodate voltage drop and ambient conditions.

Model Number	Current Range Min.- Max.	Suggested Wire Size AWG	Tightening Torque in.-lbs.	Screw / Bolt Size	Tightening Torque Nm	Suggested Wire Size ISOmm <sup>2</sup>
VMX2-18-BP	9 - 18	12	35	1 x M5 (included)	4	6
VMX2-28-BP	14 - 28	10				10
VMX2-39-BP	19 - 39	8				16
VMX2-48-BP	24 - 48	6				16
VMX2-62-BP	36 - 62	4	45	1 x M8 (included)	5	25
VMX2-78-BP	39 - 78	3				35
VMX2-92-BP	46 - 92	2				35
VMX2-112-BP	56 - 112	2				50
VMX2-150-BP	75 - 150	0	80	1 x M8 (included)	9	70
VMX2-160-BP	80 - 160	2/0				95
VMX2-210-BP	105 - 210	4/0	200	1 x 0.38" hole (M10) for User supplied lugs	15	150
VMX2-275-BP	137 - 275	300 kCMIL				185
VMX2-361-BP	180 - 361	500 kCMIL				2 x 150
VMX2-450-BP	225 - 450	2 x 250 kCMIL				2 x 150
VMX2-550-BP	275 - 550	2 x 400 kCMIL				2 x 240
VMX2-600-BP	300 – 600	2 x 500 kCMIL	TBD	TBD	TBD	2 x 300
VMX2-862-BP	431 – 862	3 x 400 kCMIL	TBD	TBD	TBD	3 x 240
VMX2-900-BP	450 – 900	3 x 500 kCMIL	TBD	TBD	TBD	3 x 300
VMX2-1006-BP	503 - 1006	4 x 350 kCMIL	TBD	TBD	TBD	4 x 185
VMX2-1250-BP	625 - 1250	4 x 500 kCMIL	TBD	TBD	TBD	4 x 300

**Table 3: VMX2 Series Wire Ranges and Torque Specifications**  
**Note: TBD = To Be Determined at a later date**

**Remote Keypad Mounting**

The keypad / operator interface unit can be remotely mounted up to 10' (3 meters) away from the starter, i.e. on the enclosure door. A remote mounting kit is necessary, which consists of an adaptor plate, a doorframe for NEMA 12 enclosures and a pre-assembled ribbon cable available in 1-meter length increments. Detailed assembly instructions and an enclosure cutout template are included with the kit. See Product Selection Guide for part numbers of the available kits.

**Figure 4**  
**Remote Keypad Mounting Kit Components**

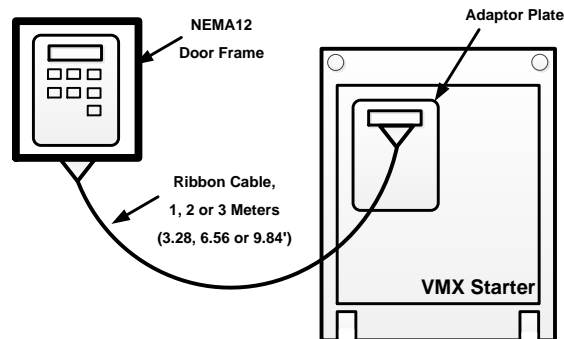

**Control Connections**

Control connections on the **VMX2 Series** starter are divided into 2 groups. With the unit oriented vertically, TB1 is a 12-point DC terminal block (on the left), and TB2 is a 10-point AC terminal block (on the right side). These are removable terminal blocks for ease of connection and servicing, and are provided with different spacing (pitch) between the header pins, so they are not interchangeable. Following are descriptions of control connection points.



- **Note:** Terminal numbers are shown on the side of the first and last terminal of each block. An additional 3 point terminal on the far left side is for serial communication connections (see section 5.6.10 of the user manual).

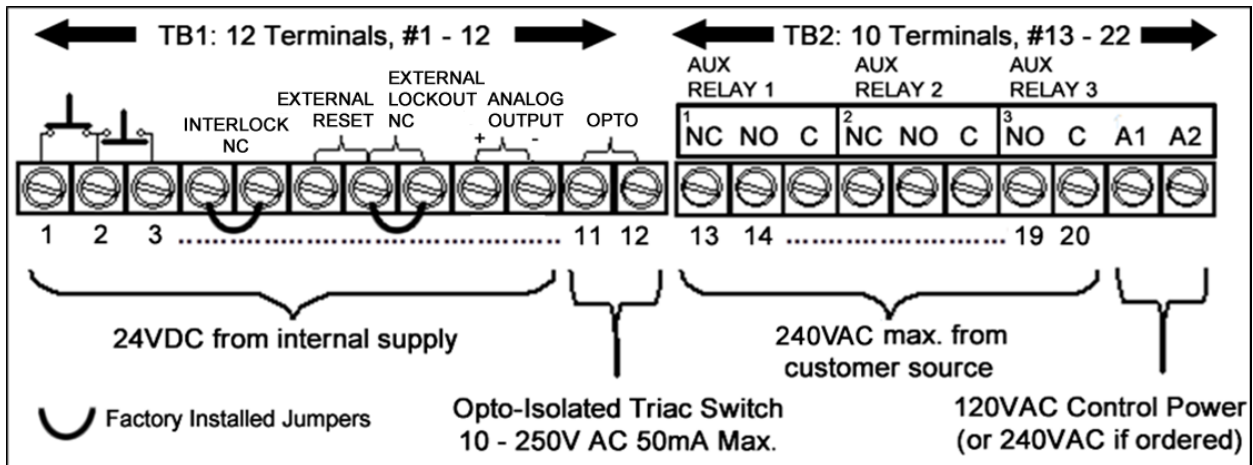

Figure 5: Control Terminal Blocks

### AC Control Power Supply Connection

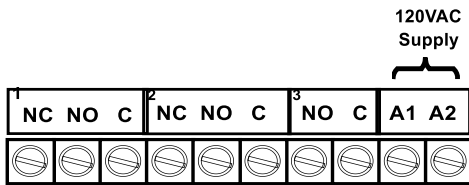

Figure 5.1  
Control Power Supply Connection  
TB-2

Separate AC Control Power supply is required to power the electronics of the **VMX2 Series** starter. The standard is 120VAC, but 240VAC (optional) can be ordered if necessary for your line power supply configuration. The control voltage must be connected to terminals marked A1 and A2 of TB-2 as shown in figure 4.2.1 (these are also Terminal No.'s 21 and 22). This control voltage must be customer supplied, unless an optional control power transformer (see table below) has been supplied with the unit.

VMX2...-BP Model	PC Boards	Fans	-BP: Bypass Contactor Inrush	-BP: Bypass Contactor Sealed	Recommended minimum CPT Rating
VMX2-18 to 48	48	(inc. in PCB)	95	9	100
VMX2-62 to 112	48	(inc. in PCB)	220	17	250
VMX2-150 to 160	48	72	298	12.3	500
VMX2-210 to 276	48	100	380	11.6	500
VMX2-360 to 450	48	150	571	14	750
VMX2-550	48	200	1000	29	1000

#### Control Power Requirements

When sizing a control power transformer for the **VMX2...-BP Series** starter use the above chart for minimum sizes or supply capacity. Any additional control devices powered by the same CPT must be added to the above values to ensure proper operation of the Bypass Contactor.

#### Control Fusing

The output relay contacts (TB2) must be protected from currents in excess of 5A by either using fuses or other suitable current protection devices.

A dedicated fault output for use in PLC or interposing relay control is available on TB1. This opto-isolated Triac switch is rated for 50mA max., 10-250V AC. Any circuit connected to it must be fused accordingly.

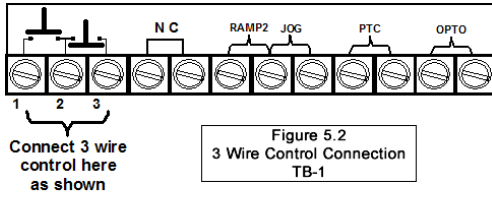

Figure 5.2  
3 Wire Control Connection  
TB-1

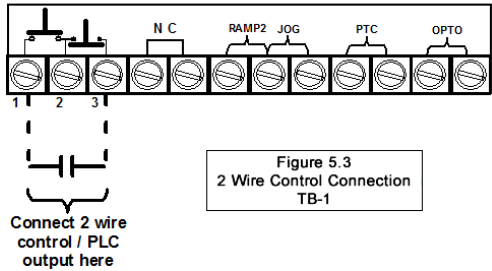

Figure 5.3  
2 Wire Control Connection  
TB-1

### Three-Wire Control Connection

For standard 3-wire control, connect dry (voltage free) contacts for the Stop / Start buttons as shown on the diagram directly above the terminal strip. Connect the N.O. contact of the Start button to Terminal 1 (far left terminal), the common point between the Stop and Start to Terminal 2 (2<sup>nd</sup> from left) and the N.C. from the Stop button to Terminal 3 (3<sup>rd</sup> from left).

- **Seal In Contact**

The **VMX2 Series** uses an internally pre-wired “seal-in” contact around the Start button (Terminals 1 and 2). No external relay or auxiliary output connection is necessary.

### Two Wire Control: Relay / PLC Connection

An alternate connection for automated or unattended operation replaces the start/stop push buttons by connecting a dry (voltage free) maintained contact closure between terminals 1 and 3 as shown in Figure 4.2.3. When this contact is closed, the **VMX2 Series** starter will start and run. When it is opened, it is the same as a Stop command.

- **Automatic Functions and 2-Wire Control**

When using the Auto Reset functions (**F052 - F053**), special consideration must be given to using 2-wire control. Refer to section 5.6.8 for details on using Auto-Reset functions.

- **Note:**

When a maintained contact is used for start/stop, it is advisable to set the overload relay to the manual reset position. This will prevent the motor from restarting if the thermal overload trips and then cools down.



### CAUTION!

**Control Terminals 1-10 of TB1 are configured using solid state devices powered internally with a 24VDC power supply. To prevent damage to the **VMX2 Series** control board, use dry (unpowered) contact closures only when connecting to these terminals.**

**If existing 120VAC or other powered control circuit must be interfaced, use isolating relays.**

### Interlock Connection

TB1 provides a connection point for an external dry (voltage free) N.C. (Normally Closed) interlock device between terminals 4 and 5. Examples where this interlock connection would be used include low oil, high temperature, or excess vibration dropout from user supplied devices. A factory-installed jumper is provided which allows the **VMX2 Series** unit to operate if external interlocks are not used. If this jumper is removed and an interlock is not used, the **VMX2 Series** unit will not function.

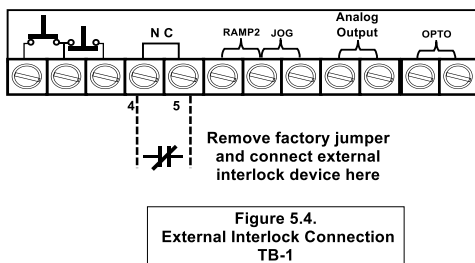
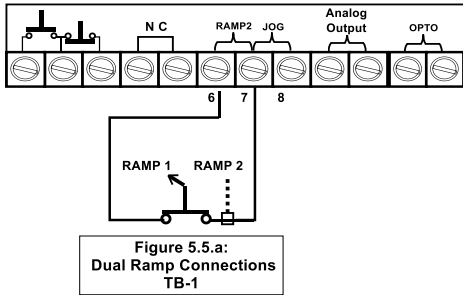

Figure 5.4.  
External Interlock Connection  
TB-1

**Enabling the Dual Ramp and Jog Features**

TB1 includes provisions for enabling the Dual Ramp and Jog functions by using external contact closures. Both features use a common +24VDC from Terminal 7. However, they can be used independently of each other or together. See sections 5.6.2 and 5.6.3 of the user manual for full function descriptions and setup.



**Note:** Ramp 2 terminals are defaulted as “External Reset”, see parameter F113 for other options.

**Dual Ramp Command**

Closing a dry (voltage free) contact between TB1, terminals 6 and 7 will enable Ramp 2, and the **VMX2 Series** starter will respond to the settings for Ramp 2 in **F015 - F018**. If no contact closure is present, the **VMX2 Series** starter defaults to the Ramp 1 parameters (**F011 - F014**). See Section 5.6.2.a of the user manual for setup of the Dual Ramp Feature.

The Dual Ramp feature is useful in instances where the load changes significantly. *Example:* a loaded or unloaded conveyor belt. The characteristics for starting an unloaded conveyor can be programmed for Ramp 1. The characteristics for starting a loaded conveyor can be programmed for Ramp 2. Ramp 2 can also be programmed for Full Voltage / Across-the-Line starting by setting the ramp time to 0 and Current to 600%.

Dual Ramp is also useful in 2-speed motor applications. Simply use an auxiliary contact from one of the speed contactors to select Ramp 2 so that separate ramp profiles can be used.

Dual Ramp input can also be configured as a “Remote reset” (See parameter F113 and associated table)

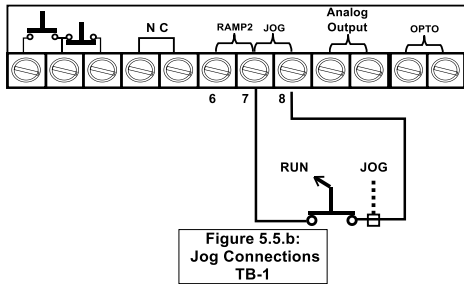

**Note:** Jog terminals are defaulted as “External Lockout, Normally Closed”, see parameter F113 for other options.

**Jog / Remote Command**

Connecting a dry (voltage free) contact between TB1, Terminals 7 and 8 will enable the Jog feature. A Start command (Run Command or Start button) is required to activate the Jog feature. See Section 5.6.3 for setup of the Jog Function.

The Jog feature can be used for tasks such as lining up machines for blade or bit changes, or inching belts along to check tracking.

This input is also used to change the function of the Serial Communications port control through **F068**. For additional information, see instructions of that function in **section 5.6.11** of the user manual.

Jog input can be also configured as:

- “Remote” (via comm. link) / “Local” (T-strip), Start stop control.
  - “External Lockout” (N.O.)
  - “External Lockout” (N.C.)
- (See parameter F113 and associated table)

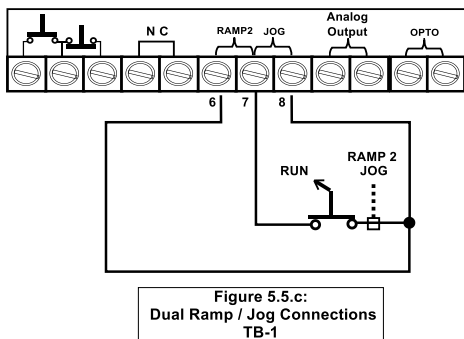

**Using Both Commands**

It may be useful to initialize the Ramp 2 and Jog command simultaneously when jogging. If this is the case, terminals 6 and 8 can be jumped together and controlled with one contact closure to Terminal 7 (the common 24VDC).

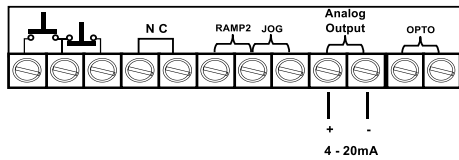

Figure 5.6:  
Analog Output Connection  
TB-1

**Analog Output (4-20mA)**

The **VMX2 Series** starter provides a 4 to 20 milliamp output signal that can be set to monitor different parameter values using F108 and scaled with parameter F109 and F110. See section 5.6.16.

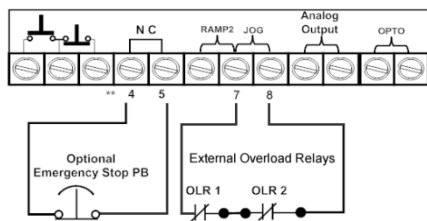

Figure 4.2.6.a:  
External Overload Relay(s)  
and/or E-Stop PB Connection  
TB-1

\*\* Remove factory jumper  
from Terminals 4 and 5

▪ **External Overload Relay Connection**

If an external Overload Relay (OLR) is used (see Section 3.1.3.c and Appendix 4), connect the N.C. aux. contact of the OLR across the Jog input (TB1 terminals 7&8), and re-program the Jog input for “External Lockout N/C”, by changing F113 per table in sect 5.6.17.

When the external OLR trips, the contact will open. This indicates an immediate Overload to the starter, which trips and displays **[LcA, Lcc, or Lcd]** depending on operation mode when the overload trips. If multiple OLRs are used, i.e. multiple motors controlled by the same **VMX2 Series** starter, simply wire the Aux Contacts in series as shown in Figure 4.2.6.a. See Appendix 4 for additional information.

▪ **Note:**



This feature is especially useful when using Deceleration Control because it will immediately shut off power to the motor even if Deceleration is active. If used this way, the trip indication will be **[LcA, Lcc, or Lcd]** depending on the operation mode when the trip is issued.



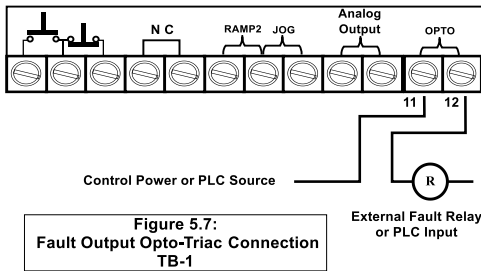

**Fault Signal**

An optically isolated Triac output is dedicated as a fault indicator on TB1, terminals 11 and 12, labeled “**Opto**”. The output Triac switch is rated for 10 - 250VAC, **50 mA (maximum)**. If the three programmable Output Auxiliary Relays are being used for other functions, this output can easily be hooked up to a PLC or small external relay to provide a Fault signal. This Fault Output operation is permanently fixed at “Any Trip”, duplicating the relay setting 22 as shown in Table 5.6.9. of the user manual.

**This output is permanently set to this function and is not programmable.**

**Output (Auxiliary) Relay Contacts**

Three programmable auxiliary relays are on TB2. The **VMX2 Series** starter comes with three programmable dry relay output contacts. Outputs 1 and 2 are Form C (SPDT), with a Common, N.O. and N.C. Output 3 is a Form A, (SPST), N.O. contact. It is not necessary to use the programmable output auxiliary relays in the Start / Stop circuit. An internal seal-in relay is provided elsewhere (see 4.2.2.a). Motronics recommends fusing all outputs with external fuses. The relays are rated for 240VAC, 5 A and 1200 VA.

Factory default settings for these relays are as follows:

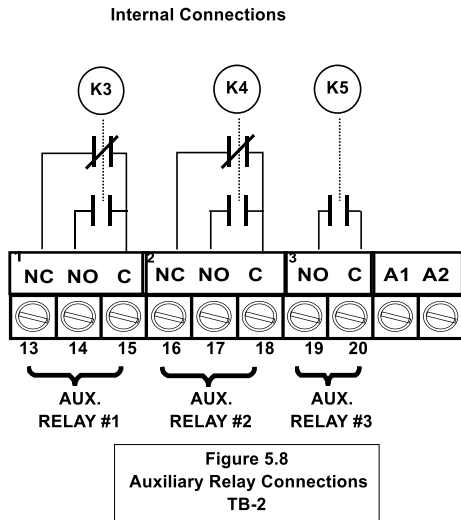

- **AUX 1 - Run / Stop** (see **F060**). This contact changes state upon a Start command, returns to normal on Stop (or Begin Decel if active).
- **AUX 2 - At-Speed / Stop** (see **F061**). This contact changes state upon the **VMX2 Series** detecting At-Speed, and returns to normal on Stop. At-Speed is determined by the **VMX2 Series** detecting the current dropping after reaching End-of-Ramp, or a maximum of 30 seconds after Start.
- **AUX 3 - Any Trip** (see **F062**) This contact closes when any trip condition 5 - 21 (as defined in Table 5.6.9 of the user manual) occurs.

**All relays can be reprogrammed for a wide variety of functions. See Section 5.6.9 of the user manual for additional relay programming details.**

**Bypass Contactor Control**

On **VMX2...-BP** version (and NEMA 12 enclosures) starters, an internal dedicated connection is used at the factory for automatically controlling the Bypass Contactor. Field wiring for Bypass Contactor operation is not required.

**▪ Independent Bypass Contactor Control**

The **VMX2...-BP Series** starters use standard industrial contactors that can be controlled independently of the starter electronics if necessary. When doing so, it is necessary to size the starter based upon the ATL (Across-the-Line) selection chart so that the contactors are rated for ATL duty instead of normal Shunt Duty. Supplemental overload protection will be required (see section 3.1.3.c of the user manual).

Units have external terminal blocks marked for this purpose (see Appendix 4 for drawings). A dry (voltage free) contact closure between these terminals will close the bypass contactor immediately. The Bypass Contactor coil voltage is the same as the control voltage (120VAC unless the optional 240VAC control is specified), and the voltage on these terminals is the same as the coil voltage.

**No field wiring is necessary to these terminals if this feature is not used.**

For all other styles of **VMX2 Series**, the At-Speed signaling can be programmed into any of the three Output relays (section 4.2.8 and Table 5.6.9 of the user manual).

No field wiring is necessary to these terminals if this feature is not used.

VMX2 Bypass Control Terminal Location Diagrams

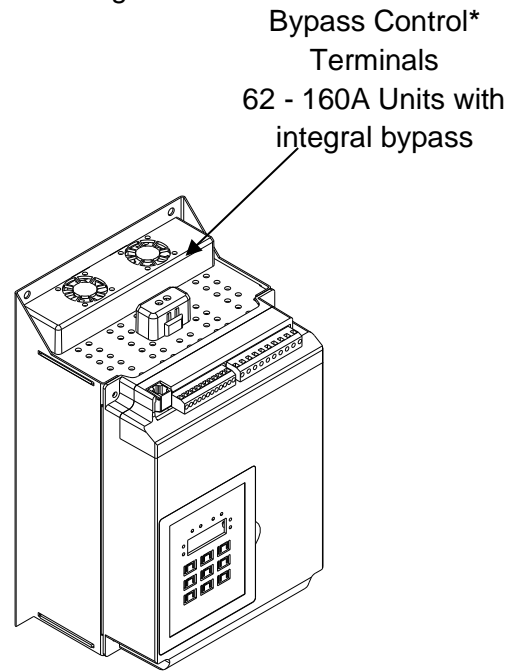
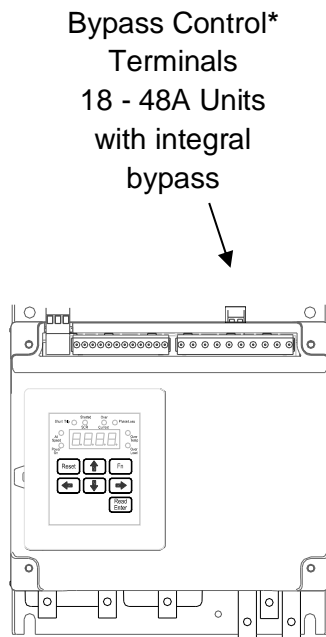

**Note:** Use these terminals only when separate control of the Bypass Contactor is necessary.

Bypass Control  
Terminals  
210 - 600A with  
integral bypass

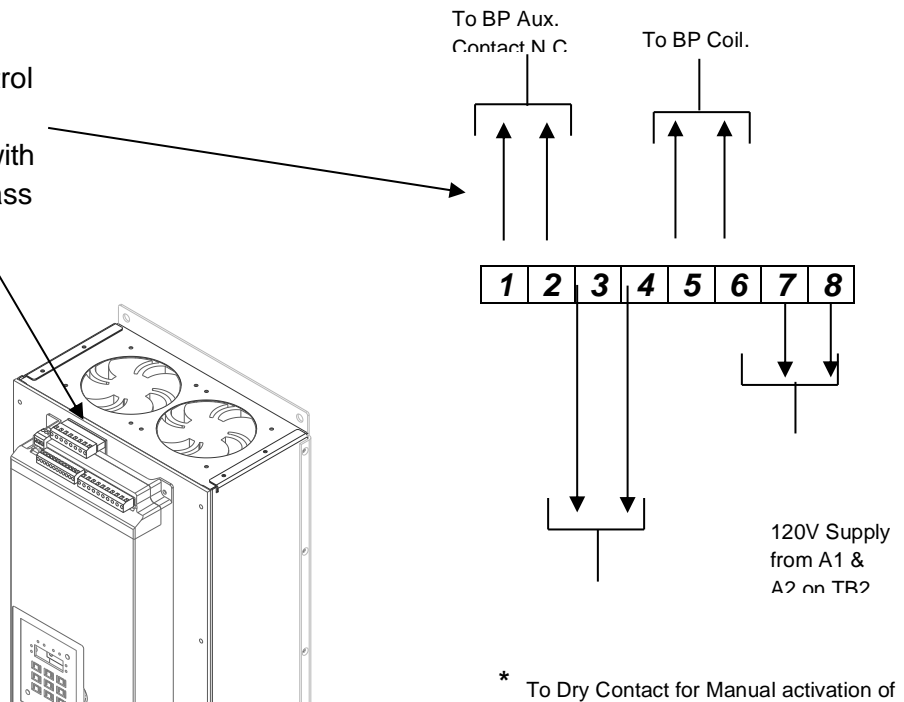

## Chapter 3 - Sequence of Operation

### Starting:

1. Apply three phase power to the unit. The motor should not run until a Start command is applied.
2. Apply control power and check that the “Power On” LED comes on.
3. Status Display should read **[0000.]** showing no current in Phase A (minor flickering of the first digit is common).
4. Apply the Start (Run) command. The motor should begin to accelerate. Status display will read Phase A Amps at an increasing rate.
5. When the motor reaches full speed, the “At Speed” LED comes on and the Bypass Contactor will close. Status display should show a sharp decrease in Phase A Amps.
6. If the motor does not fully accelerate, decelerates, or stops during the acceleration period, hit the Stop button immediately and open the disconnect line.

### Stopping:

If Pump-Flex Decel is Disabled (factory default) in F024:

1. Remove the Run Command (or hit the Stop button).
2. At-Speed LED will go out and Bypass Contactor will open. Status display should read **[0000.]** indicating no current on Phase A.
3. Motor will coast to a stop according to load inertia and friction.

If Pump-Flex Decel is Enabled in F024:

1. Remove the Run Command (or hit the Stop button).
2. At-Speed LED will go out and Bypass Contactor will open. Status display should briefly read Phase A Amps increasing as motor begins to decelerate.
3. Motor should begin to slow down. Status display should begin to show decreasing motor amps.
4. When motor reaches Stop Level, VMX2 should turn off. Status display will again show **[0000.]**

If the unit does not follow this operational sequence please contact the factory or refer to the VMX2 Series Troubleshooting Guide.

## Chapter 4 – Programming

It is best to operate the motor at its full load starting conditions to achieve the proper time, torque and ramp settings. Initial factory settings are set to accommodate general motor applications and provide basic motor protection. Advanced features must be enabled via programming. The only parameter that **MUST** be set by the user is motor FLA (**F001**).

**Digital Interface:** The *VMX2 Series Soft Starter* includes a digital keypad with eight LEDs, seven command keys, and an LED display with four alphanumeric digits.

Table 5.: VMX2 Series Display Features		
Keys	Reset	Clears the Trip indication and releases the Trip Relay.
	Fn	Enters or exits the Program Mode.
	Up and Down Arrows	Navigates through the Status Display Mode, scrolls up and down through the Function List, increases or decreases the value of the active (flashing) digit and scrolls through the fault history. When entering values, holding the key down for more than 2 seconds will activate Auto-step, which increases its rate the longer the key is held down.
	Right and Left Arrows	Each key press shifts the active (flashing) digit to the right or left by one position, allowing you to change higher values of functions without waiting to Auto-step though large numbers.
Green LEDs	Power On	Control power is available at A1 and A2
	At Speed	The motor is at full power and the Bypass Contactor has been commanded to pull in. The SCRs are at full conduction and current has dropped.
Yellow LEDs	Shunt Trip	Power is flowing to the motor in the Off mode. See section 5.6.8.a of the Advanced Installation, Operation and Programming Manual for additional information.
	Shorted SCR	There is no voltage drop across at least one SCR phase assembly, indicating that at least one SCR is shorted. See section 7 of the Advanced Installation, Operation and Programming Manual for additional information.
	Over Current	Overcurrent LED lights for three sets of fault conditions: 1) During start, the unit saw current exceed the normal rate of increase in the first 250ms. 2) During Run, current exceeded either the OC setting in <b>F042</b> for the delay set in <b>F043</b> . This LED will be accompanied by <b>oCA</b> , <b>oCC</b> or <b>oCd</b> on the display. 3) The unit has seen a Short Circuit exceeding 10x FLA for 12.5ms. This LED will be accompanied by <b>SCA</b> , <b>SCC</b> or <b>SCD</b> display.
	Phase Loss	One or more of the phase currents dropped below the threshold during starting or running.
	Over Temp	Starter has tripped due to excess heat sink temperature. This will automatically reset.
	Over Load	Starter has tripped due to the Thermal Register reaching 0000. The Overload must reset before this fault can be cleared.
Display	8888.	4 digit 7 segment display with a decimal point on the right side indicating Phase A.

**MOTOR FLA (F001)  
must be programmed  
for unit to operate!**



Figure 6.

**Display Modes**

There are three modes of display: The Status Display Mode, the Program Mode, and the Fault Mode.

**Status Display Mode (Default Display)**

The Status Display Mode displays seven “screens” of information. Motor Currents (3 phases), Remaining Thermal Capacity, Ground Current, Remaining Time on the Process Timer, and Time Base of the Time Clock Controller. This is also the entry screen for going into the Program Mode.

Status mode:

**[0000.]** The initial display on power up is four digits and the decimal. This indicates the motor current for Phase A of the motor.

**[0000]** Scroll UP to display four digits only (no decimal). This indicates the motor current for Phase B. While viewing Phase B, press the UP arrow again to view Phase C current.

**[G000]** Scroll UP to display the “G”. This shows the value of the current flowing to ground on the motor leads.

**[H000]** Scroll UP to display the “H”. This indicates the value of the remaining thermal capacity percentage of the motor (i.e. H070 = 70% remaining thermal capacity)

**Program Mode**

The starter must be STOPPED in order to enter the Program Mode. Use the Program Mode to view or change Function (Fn) settings. To enter the Program Mode, press the **[Fn]** key once from the Status Screen described in section 5.3.1 of the **Advanced Installation, Operation and Programming Manual**. The first time you enter the Program Mode after power has been cycled to the starter, the initial function **[F001]** should be displayed with the selected digit flashing. If the **VMX2 Series** starter has been programmed and power to the unit has not been cycled, the readout will display the last function viewed or changed. To change to a different function, use the arrow keys.

**Viewing Function Programming and Values**

The programming of each individual Function can be viewed without making changes (values can also be viewed in the Run Mode however, no changes can be made). Each Function is signified by the letter “F” in the beginning of the data, the 4 digit value of the function follows after pushing the **[READ/ENTER]** key

- **[F001]** The “F” indicates the programmable Function.
- **[0000]** This is the present setting of the applicable function.

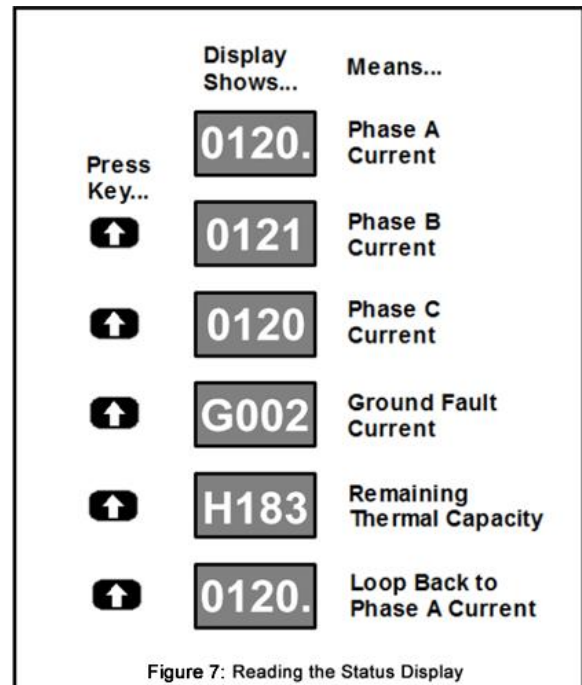

Figure 7: Reading the Status Display

This display may include decimals between digits depending on the function setting’s range and incremental steps **[F001]** The “F” indicates the programmable Function.

**[0000]** This is the present setting of the applicable function. This display may include decimals between digits depending on the function setting’s range and incremental steps.

Pressing the **[Fn]** key again will return to the Function display without making changes.

## Changing a Function's Set Value

From the instructions above, after pressing the **[READ/ENTER]** key the display will show the value of that function with one digit flashing (usually the rightmost digit). Flashing indicates this is the digit to be altered (similar to cursor position). Use the UP arrow key to increment the value of the flashing digit. Use the DOWN arrow key to decrement the value of the flashing digit. Use the LEFT or RIGHT arrow to select the next digit to be altered. Values can only be changed within the Adjustment Range of the function parameter.

Pressing the **[READ/ENTER]** key again will store the new programming for that Function and return to the Function display.

If the display shows **[Inh]** when trying to store the changes, the unit is running and must be Stopped, or a Password has been set up to prevent access and must be entered first. See section 5.6.11 of the Advanced Installation, Operation and Programming Manual for details about this feature.



### Caution!

**If the Fn key is pressed or power is lost before the [READ/ENTER] key is pressed, the VMX2 Series Starter will not store the selected value in memory.**

## Fault Mode

The Fault Mode Display provides information to the operator when a fault occurs and allows the operator to review fault history. Refer to described in Section 7 of the Advanced Installation, Operation and Programming Manual for details. Fault codes are displayed by 3 alpha characters. The first and second characters (reading left to right) are the initials for the applicable English-language fault name. The third or right-most character can be either A, c, or d to denote when the fault occurred. "A" denotes Acceleration. "c" denotes Constant speed. "d" denotes Decel or Stopped.



**Example 1: Figure 8**

**Entering a new FLA setting into Function 001**

**Viewing a Function’s Set Value**

**[0000.]** Indicates Phase A is drawing no current (unit is in Off mode).

**Press the [Fn] key**

**[F001]** Indicates this is Function 001 (Motor FLA).

**Press [READ/ENTER] key to view the F001 value**

**[0048]** Indicates the programmed motor FLA is 48 Amps. The right most digit (8) is flashing, indicating that this is the digit that you will alter (cursor position).

**Press the UP Arrow key to increase this digit value**

**[0049]** Indicates you have increased the right most digit to a value of 9.

**Press the LEFT Arrow key to shift left to the next digit**

**[0049]** The second digit from the right is now flashing, indicating a new cursor position.

**Press the UP Arrow key to increase this digit value**

**[0059]** Indicates you have increased the 2<sup>nd</sup> to right digit to a value of 5 (10’s place).

**Press [READ/ENTER] key to store the new value**

**[End]** The word “End” will flash briefly to indicate that the new value has been entered and accepted. After flashing once, the display will revert to showing the Function number.

**Press the [Fn] key**

**[0000.]** Returns to the Default Display, indicating Phase A is drawing no current

**Note:** When first entering FLA into a new unit, pressing the Up arrow key will jump the readout value immediately to ½ of the unit Max. Amp rating and it will never go below that again. Any unit thought to be new which has a value other than 0000 in F001 upon setup, has been programmed previously and should be reset to factory defaults before proceeding.

**Example 1: Setting the Motor FLA**

**Change FLA from 48 to 59A**

Press Key...	Display Shows...	Means...
		Phase A Current
		Function #1 Selected
		Previous Setting of Function #1
		New Value of First Digit
		Cursor (flashing) Position Shift
		New Value of Second Digit
		Value Accepted (flashes once)
		Return to Function # Display

Figure 8: Changing a Function Value

Parameter Function List

**Motor FLA, Service Factor and Overload Protection Functions**

Fn #	Group	Function Description	Adjustment / Display Range	Setting Increments	Factory Setting	User Manual Section
F001	Motor and Overload Info.	Motor Nameplate FLA FLA must be programmed for starter to function.	50 - 100% of Max Amp Rating. Upper limit of range automatically adjusts downward as Service factor is increased.	1 amp	0	5.6.1 and 3.2
F002		Motor Nameplate Service Factor	1.00 - 1.30 SF	0.05	1.0 SF	
F003		Overload Class During Start	NEMA / UL Class 5 -30	5	Class 10	
F004		Overload Class During Run	NEMA / UL Class 5 - 30	5	Class 10	
F005		Overload Reset	0 = Manual 1 = Auto 2 = Disabled Overload	1	0 (Manual)	
F006-F009		Reserved for factory use				

**Starting Mode Functions**

Fn #	Group	Function Description	Adjustment / Display Range	Setting Increments	Factory Setting	User Manual Section
F010	Starting and Stopping Modes	Ramp Type Selection: VR = Voltage Ramp CR = Current PID Ramp 1 = Ramp 1, 2 = Ramp 2	Setting 1 = VR1 + VR2 Setting 2 = CR1 + CR2 Setting 3 = VR1 + CR2 Setting 4 = CR1 + VR2	1	1 VR1+VR2	5.6.2 and Append. 1
F011		Initial Torque (VR) of Ramp 1	0 - 100% Line Voltage	1%	60%	
F012		Initial Torque (CR) of Ramp 1	0 - 600% Motor Current	1%	200%	
F013		Accel Ramp Time of Ramp 1	1 - 120 seconds	1 second	10 seconds	
F014		Max Current Limit of Ramp 1	200 - 600% Motor Current	1%	350%	
F015		Initial Torque (VR) of Ramp 2	0 - 100% Line Voltage	1%	60%	5.6.2, Append. 1 and 4.2.5
F016		Initial Torque (CR) of Ramp 2	0 - 600% Motor Current	1%	200%	
F017		Accel Ramp Time of Ramp 2	1 - 120 seconds	1 second	10 seconds	
F018		Max Current Limit of Ramp 2	200 - 600% Motor Current	1%	350%	

**Jog Mode Functions**

Fn #	Group	Function Description	Adjustment / Display Range	Setting Increments	Factory Setting	User Manual Section
F019	Jog Modes	Voltage Jog	5 - 100% Line Voltage	1%	50%	5.6.3 and 4.2.5.b
F020		Time of Voltage Jog	1 - 20 Seconds	1 second	10 seconds	
F021		Current Jog	100 - 500% Motor Current	1%	150%	

**Kick Start Mode Functions**

Fn #	Group	Function Description	Adjustment / Display Range	Setting Increments	Factory Setting	User Manual Section
F022	Kick Mode	Kick Start Voltage	0 = Disabled, or 10 - 100% Line Voltage	1%	0 Disabled	5.6.4
F023		Kick Start Time	0.1 - 2 Seconds	0.1second	0.8 seconds	

**Decel Mode Functions**

Fn #	Group	Function Description	Adjustment / Display Range	Setting Increments	Factory Setting	User Manual Section
F024	Pump-Flex Decel Mode	Pump-Flex Control / Deceleration Ramp	0 = Disabled (coast to stop) 1 = Enabled, Power OFF on OL trip Enabled, Decel even if there is an OL trip	1	0 Disabled	5.6.5 and Append. 2
F025		Begin Decel Level (BDL), Immediate Drop Down Torque	0 - 100 % of Output Voltage	1%	60%	
F026		Decel Shut Off Voltage	0 to (BDL minus 1)% Voltage	1%	30%	
F027		Decel Ramp Time	1 - 60 Seconds	1 second	10 seconds	

**Restart Function**

Fn #	Group	Function Description	Adjustment / Display Range	Setting Increments	Factory Setting	User Manual Section
F028	Restart	Auto Restart Delay Time (Sequential Start Delay)	0 = Disabled, or 1-999 seconds after a Power Loss (Status can be read in F054)	1 second	0 Disabled	5.6.6

**Line Voltage**

Fn #	Group	Function Description	Adjustment / Display Range	Setting Increments	Factory Setting	User Manual Section
F029	Line Voltage	Voltage Input	200 - 690 Volt	1	480	5.6.7
F030		Voltage Imbalance Trip %	0, 1 - 30% [0=Disabled]	1(%)	0	
F031		Voltage Imbalance Trip Delay	1 - 20 seconds	1	10	
F032		Over Voltage Trip %	0, 1 - 10% [0=Disabled]	1(%)	0	
F033		Over Voltage Trip Delay	1 - 20 seconds	1	10	
F034		Under Voltage Trip on Start %	0, 1 - 20% [0=Disabled]	1(%)	0	
F035		UV Trip on Start Delay	1 - 180 seconds	1	10	
F036		Under Voltage Trip on Run %	0, 1 - 20% [0=Disabled]	1(%)	0	
F037		UV Trip Delay during Run	1 - 20 seconds	1	2	
F038		Shorted SCR and Trip Delay	0, 1-10 seconds [0=Disabled]	1 second	1 second	
F039		Shunt Trip Delay	0, 1-10 seconds [0=Disabled]	1 second	1 second	

**Current and Ground Fault Protection Features**

Fn #	Group	Function Description	Adjustment / Display Range	Setting Increments	Factory Setting	User Manual Section
F040	Phase Current	Current Imbalance Trip	0, 5 - 30% [0 = Disabled]	1%	0 Disabled	5.6.8
F041		Current Imbalance Trip Delay	1 - 20 seconds	1 second	2 seconds	
F042		Over Current Trip	0, 100 - 300% of motor FLA [0 = Disabled]	1%	0 Disabled	
F043		Over Current Trip Delay	1 - 20 seconds	1 second	1 second	
F044		Under Current Trip	0, 10 - 90% of motor FLA [0 = Disabled]	1%	0 Disabled	
F045		Under Current Trip Delay	1 - 60 seconds	1 second	2 seconds	
F046		Ground Fault Trip	0, 5 - 90% of CT ratio from Fn 074 [0 = Disabled]	1%	0 Disabled	
F047		Ground Fault Trip Delay	1 - 60 seconds	1 second	2 seconds	

**Lockouts, Reset and Internal Protection Functions**

Fn #	Group	Function Description	Adjustment / Display Range	Setting Increments	Factory Setting	User Manual Section
F048	Lockouts, Reset and Internal Protection	Coast Down (Back Spin) Lockout Timer	0 - 60 minutes [0 = Disabled]	1 minute	0 Disabled	5.6.9
F049		Maximum Starts per Hour	0 - 10 starts [0 = Disabled]	1	0 Disabled	
F050		Minimum Time Between Starts	0 - 60 minutes [0 = Disabled]	1 minute	0 Disabled	
F051		nCP Trip (No Control Power)	0, 1 [0=Disabled, 1=Enabled]	1	0	5.6.9.a
F052		Auto Reset on Selected Faults	Fault Preferences 1 - 17 See Table 5.6.7: "Auto-Reset Selected Faults"	1	4, Phase Loss only	5.6.9.b
F053		Auto Reset Attempts	0 - 10 attempts [0 = Disabled] [In 1 minute cycle]	1	0 Disabled	
F054		Restart Delay Time Value Readout (for F028)	0 - 999 Seconds	-	Read Only	5.6.9.c
F055		Coast Down Timer Value for F048	1 - 3600 Seconds	-	Read Only	
F056		Starts Per Hour Timer Value for F049	1 - 3600 Seconds	-	Read Only	
F057		Starts Per Hour For F049	1 - 10 Starts	-	Read Only	
F058		Time Value Between Starts for F050	1 - 3600 Seconds	-	Read Only	
F059		Thermal Capacity to Start for F005	0 - 100 % Thermal Capacity	-	Read Only	

**Output Relay Programming Features**

Fn #	Group	Function Description	Adjustment / Display Range	Setting Increments	Factory Setting	User Manual Section
F060	Output Relays	Aux Relay 1 setting	Operation # 1 - 32: see "Aux. Relay Settings Chart"	1	1	5.6.10
F061		Aux Relay 2 setting	Operation # 1 - 32: see "Aux. Relay Settings Chart"	1	2	
F062		Aux Relay 3 setting	Operation # 1 - 32: see "Aux. Relay Settings Chart"	1	22	
F063		Aux. Relay Delay Timer (for Operations 28-31)	0 - 999 seconds [0 = Disabled]	1 second	0 No Delay	
F064		Reserved for factory use				



**Notes:**

Check wiring to each relay before changing programming to ensure there are no unintended consequences. Relays programmed to some protection features will not operate if function is disabled elsewhere.

**Serial Communications**

Fn #	Group	Function Description	Adjustment / Display Range	Setting Increments	Factory Setting	User Manual Section
F065	Communications	Communications	0 = Disabled 1 = Enabled (11Bit) 2 = Enabled (10Bit)	1	0	5.6.11
F066		Baud Rate	4.8, 9.6 and 19.2 KB	3 rates	9.6 KB	
F067		Modbus Address	1 - 247	1	1	
F068		Remote Starter Control	0 = Disabled 1 = Enabled w/ Start button 2 = Enabled w/o Start button 3 = Enabled via Jog-Remote Input  <b>See parameter F113 as well.</b>	1	0	
F069		Reserved for factory use				

**System Settings**

Fn #	Group	Function Description	Adjustment / Display Range	Setting Increments	Factory Setting	User Manual Section	
F070	System Settings	Parameter Lock Customer Password	0 - 999 0 = Disabled Any Other Numbers = Password	1	0 (displays encrypted code)	5.6.12 and Append. 3	
F071		System Clear / Reset	0 = Disabled 1 = Clear THR and Lockout Timers 2 = Reset to Factory Default Settings	1	0	5.6.12	
F072		Reserved for Factory Use					
F073		Frame Rating	10 – 2000 Factory set	1	By Model (defaults to 48)	5.6.12	
F074		CT Value	10 – 2000 Factory set	5	By Model (defaults to 40)		
F075		Year	2000 - 2047	1 year	2000	5.6.12.a	
F076		Month	1 - 12	1 Month	1		
F077		Day	1 - 31	1 Day	1		
F078		Hour	0 - 23	1 Hour	0		
F079		Minute	0 - 59	1 Minute	0		
F080		Second	0 - 59	1 Second	0		
F081		Revision #	-	-	-	Factory Setting	
F082 - F084		Reserved for factory use					

**Fault History and Run Time**

Fn #	Group	Function Description	Adjustment / Display Range	Setting Increments	Factory Setting	User Manual Section
F085	Fault History and Run Data	Fault History #1, Latest Fault	0 = No fault history, or Fault # 1 - 57: see Fault code list	N/A	Read Only	5.6.13.a
F086		Time Stamp, Fault #1 Based on F078-80	23.59 (hh.mm) [hh = 00 - 23; mm = 00 - 59]			
F087		Date Stamp, Fault #1 Based on F076-77	01.01 - 12.31 (MM.DD) [MM = 01 - 12; DD = 01 - 31]			
F088		Fault History #2, Previous Fault	0 = No fault history, or Fault # 1 - 57: see Fault code list			
F089		Time Stamp, Fault #2	00.00 - 23.59 (hh.mm) [hh = 00 - 23; mm = 00 - 59]			
F090		Date Stamp, Fault #2	01.01 - 12.31 (MM.DD) [MM = 01 - 12; DD = 01 - 31]			
F091		Fault History #3, Oldest Fault	0 = No fault history, or Fault # 1 - 57: see Fault code list			
F092		Time Stamp, Fault #3	00.00 - 23.59 (hh.mm) [hh = 00 - 23; mm = 00 - 59]			
F093		Date Stamp, Fault #3	01.01 - 12.31 (MM.DD) [MM = 01 - 12; DD = 01 - 31]			
F094		Run Time, Hours	000.0 - 999.9 hours			5.6.13.b
F095		Run Time, 1000 Hour Overflow	0000 - 9999 thousand hours			
F096		Run Cycle Counter	0000 - 9999 times			
F097		Run Cycle Counter 10K overflow	0000 - 9999 10 thousand times			

**Phase Protection Settings**

Fn #	Group	Function Description	Adjustment / Display Range	Setting Increments	Factory Setting	User Manual Section
F098	Phase and Frequency Protection	Phase Rotation Trip	0, 1 or 2 0=Disabled, 1=ABC, 2=ACB]	1	0	5.6.14
F099		Phase Rotation Trip Delay	1 - 3 seconds	1	1	
F100		Phase Loss Trip Delay during Stop	0 - 20 seconds [0 = Disabled]	1	1	
F101		Phase Loss Trip Delay during Running	0 - 20 seconds [0 = Disabled]	1	3	

## Motor Power Protection Settings

Fn #	Group	Function Description	Adjustment / Display Range	Setting Increments	Factory Setting	User Manual Section
F102	Power Protection	Motor kW Trip	0 - 2 0 = Disabled 1 = Over kW Trip 2 = Under kW Trip	1	0	5.6.15
F103		Motor kW Trip Point	20 - 100% of full load KW	1%	50(%)	
F104		Motor kW Trip Delay Time	1 - 999 seconds	1	1	
F105		Power Factor Trip Range	0, 1 - 3 [0=Disabled, 1=l原因, 2=lead, 3=lead/lag]	1	0	
F106		Power Factor Trip Point	.01 - 1	.01	.50	
F107		Power Factor Trip Delay Time	1 - 20 seconds	1	2	

## Analog Output

Fn #	Group	Function Description	Adjustment / Display Range	Setting Increments	Factory Setting	User Manual Section
F108	Power Protection	Analog Output	0 - 12 [0: OFF; 1 - 12] (See Table of Default Display)	1	OFF	5.6.16
F109		Analog Output 4mA	0 - 9999	1	0	
F110		Analog Output 20mA	0 - 9999	1	9999	

## Display and System Settings

Fn #	Group	Function Description	Adjustment / Display Range	Setting Increments	Factory Setting	User Manual Section
F111	System Settings	Default Display	1-12 (See Table of Default Display)	1	10	5.6.17
F112		System Settings	Reserved for factory	-	-	
F113		Alternate functions for Ramp2/Jog inputs	See Table F113 user manual page 64	1	7	



**Auxiliary Output Relay Settings**

Functions F060 through F062 provide the ability to program the functions of each of the 3 Output Auxiliary Relays. Factory default programming is provided which covers a wide variety of applications, but any of these relays can be changed as per the following chart.



**Notes:**

Check relay wiring before changing programming to avoid unintended consequences. Relays programmed to some protection features will not operate if function is disabled elsewhere.

Setting	Relay Operation Description	Setting	Relay Operation Description
1	Run / Stop	17	Over Voltage Trip
2	At Speed / Stop	18	Under Voltage Trip During Start
3	At Speed / End of Decel	19	Under Voltage Trip During Run
4	Start / End of Decel	20	Power Factor Trip
5	Short SCR Trip	21	Power Trip
6	Phase Loss Trip	22	Any Trip
7	Shunt Trip	23	Any Trip, flashing output
8	OL Trip	24	Coast Down Time Lockout
9	OT Trip	25	Starts Per Hour Lockout
10	Short Circuit Trip	26	Time Between Starts Lockout
11	Current Imbalance Trip	27	Any Lockout
12	Over Current Trip	28	Run / Stop with On-delay from F063
13	Under Current Trip	29	At Speed / Stop with On-delay from F063
14	Ground Fault Trip	30	At Speed / End of Decel with On-delay from F063
15	Phase Rotation Trip	31	Start / End of Decel with On-delay from F063
16	Voltage Imbalance Trip	32	Power Loss (nCP No Control Power) Trip

\*Note: Flash rate for Setting #23 is ½ second On and Off

**Table 7: Aux. Relay Settings**

**Fault Mode**

The **VMX2 Series** will automatically enter the Fault Mode when a fault occurs in the motor or starter and display a code indicating the condition that caused a shutdown. Fault codes are three-digits in length and are displayed in alpha characters. The first and second characters (reading left to right) are the initials for the applicable English-language fault name. The third or right-most character can be either A, c, or d to denote when the fault occurred. “A” denotes Acceleration. “c” denotes Constant speed. “d” denotes Decel or Stopped.

A **Fault History** of the past 3 events is stored and can be accessed by using the Up or Down Arrow keys before pressing the Reset button. The first (newest) event is indicated by the decimal point in the lower right corner. A more detailed history with time and date stamps is also kept in Functions 85 through 93.

**Fault Codes:**

Basic common fault codes are shown in the chart below. For additional details refer to Chapter 7 of the Advanced Installation, Operation and Programming Manual, or contact the factory for assistance.

Fault Condition Description	Fault Display Code Readout	Fault Number Code used in History, F085, F088 and F091	LED Indicator
Over Current during Accel; Const spd; Decel	ocA; occ; ocd	1; 2; 3	Over Current
Phase Loss during Accel; Const spd; Decel	PLA; PLC; PLd	4; 5; 6	Phase Loss
Over Temperature during Accel; Const spd; Decel	otA; otc; otd	7; 8; 9	Over Temp
Over Load during Accel; Const spd; Decel	oLA; oLc; oLd	10; 11; 12	Over Load
Shorted SCR during Accel; Const spd; Decel	SSA; SSc; SSd	13; 14; 15	Shorted SCR
Shunt Trip during Accel; Const spd; Decel	st	16; 17; 18	Shunt Trip
Current Imbalance during Accel; Const spd; Decel	lba; lbc; lbd	19; 20; 21	---
Under Current during Accel; Const spd; Decel	UcA; Ucc; Ucd	22; 23; 24	---
Short Circuit during Accel; Const spd; Decel	ScA; Scc; Scd	25; 26; 27	Over Current
Ground Fault during Accel; Const spd; Decel	GfA; Gfc; Gfd	28; 29; 30	---
Bypass Discrepancy during Accel; Const spd; Decel	bPA; bPc; bPd	31; 32; 33	---
External Lockout Trip during Accel; Const spd; Decel	LcA; Lcc; Lcd	34; 35; 36	Over Load
Rotation Trip during Accel; Const spd; Decel	rtA; rtc; rtd	37; 38; 39	---
Voltage Imbalance during Accel; Const spd; Decel	EIA; EIC; EID	40; 41; 42	N/A
Over Voltage during Accel; Const spd; Decel	OEA; OEC; OED	43; 44; 45	
Under Voltage during Accel; Const spd; Decel	UEAIUEC; UED	46; 47; 48	
Power Factor during Accel; Const spd; Decel	PfA; Pfc; Pfd	49; 50; 51	
PowerR during Accel; Const spd; Decel	PRA; PRC; PRD	52; 53; 54	
Control Power Loss during Accel; Const spd; Decel	nCPA, nCPC, nCPD	55; 56; 57	

**Additional codes that may be displayed**

Display Code Readout	Condition Description
nFLA	<b>No Full Load Amps set in F001</b>
Inh	<b>Inhibit:</b> Starter is still in Run mode when you are attempting a change in programming, or the starter has Password Protection enabled and you have not entered the password code.
n3Ph	<b>No 3 Phase:</b> No input line voltages on any phase.
Loc	<b>Lockout:</b> The unit has tripped on Overload and you are attempting to Reset before it is ready, or one of the Duty Cycle Lockout protection features has been enabled.
Err	<b>Error:</b> You are attempting to enter an invalid password

**Table 8: Fault and Display code list**

## Chapter 5 - Motor Overload Protection

### Solid State Overload Protection

The **VMX2 Series** Starter provides true U.L. listed I<sup>2</sup>t Thermal Overload Protection as a built-in function of the main digital processor for maximum motor protection. It simulates the tripping action of a bi-metallic overload relay, with the accuracy and repeatability of a digital control system. It is adjustable over a wide range and can be easily programmed for different trip curves.

#### Thermal Memory

The **VMX2 Series** microprocessor uses a sophisticated “Thermal Register” in the digital memory to keep track of motor heating and cooling over time regardless of the starter’s power status. By using non-volatile memory, the **VMX2 Series** does not “forget” that the motor has been running even if power to the starter is turned off and back on. Continuous overload protection is provided based on the true thermal condition of the motor.

#### Thermal Capacity

The Thermal Register is displayed as a percentage. This percentage is the motor’s remaining thermal capacity. The percentage value begins at 100, showing that the motor is cool (has 100% of its capacity available). As the motor heats up or moves toward an overload condition, the percentage begins to drop. The Thermal Capacity is derived from the programmed motor nameplate Full Load Amps (FLA) in Function F001, the Service Factor rating in Function F002, and the Overload Trip Class in Functions F003 and F004. Setting these functions to the proper values provides maximum protection and eliminates nuisance tripping.

#### Examples:



100% Thermal  
Capacity remaining  
at rest

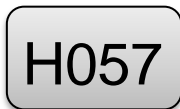

57% Thermal  
Capacity remaining  
after starter (43%)



The Remaining Thermal Capacity can be viewed by using the UP or DOWN arrow keys when in the Status Display mode. From the default Phase A Current screen (dot on right side), press the UP arrow key 4 times to display **[H100]** meaning there is 100% of the Thermal Capacity (H = Heat capacity) remaining in the motor. After starting or running, the motor will use this capacity and the display will show a lower number. For example, after a cold start, the display may read **[H065]** which indicates that the motor has 65% of its thermal capacity remaining (35% used). The Status Display screens cycle back to the beginning, so the Down arrow keys can get to this display as well.

#### Motor Full Load (FLA) Setting

Use Function F001 to enter motor FLA as indicated on the motor nameplate. (Do not calculate for service factor, this is programmed separately in F002).

#### Note:

All **VMX2 Series** starters are shipped from the factory with F001 set to a default value of 0000. If F001 is left at the factory default, the unit will not operate. If the user attempts to start the **VMX2 Series** without entering the motor nameplate FLA, the starter will Fault and the display will read “nFLA” (no Full Load Amps).

#### Disabling the Overload Protection

The Overload Protection feature can be disabled if necessary. Please refer to the Advanced Installation, Operation and Programming Manual for instructions and considerations before disabling the Overload Protection



#### WARNING!

**Do NOT disable Overload Protection unless another Thermal Overload Protection device exists in the circuit for all three phases. Running a motor without Overload Protection presents serious risk of motor damage or fire.**

### Manual Reset

The factory default setting is Manual Reset. This means that when the Overload Trip is activated, the starter cannot be restarted without pressing the Reset key. The Overload Trip will not reset until the motor cools down (see 3.1.3.d of the user manual). The Manual Reset function is also “trip free”. Holding in the Reset key will not prevent the Overload Trip from activating and protecting the motor.



**Note:**

When the Overload Trip activates, the Overload LED will glow solid. When the motor cools down, the LED will begin to flash, indicating that the Overload Trip can be reset.

### Automatic Reset

If Automatic Reset is necessary, change from Manual Reset to Automatic Reset by using Function F005. (See Section 5. of the Advanced Installation, Operation and Programming Manual for details). In this mode, a 3-wire control circuit will be capable of restart when the **VMX2 Series** has reset itself after the cool down period.

**WARNING!**

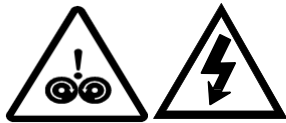

**Two-wire control systems may restart without warning when Auto Reset is selected. Extreme caution should be exercised. To prevent automatic restarting with 2-wire control systems, use external interlocking to provide sufficient warning and safety to operators. A Warning Label similar to that shown below (and the one provided in the packet with this manual) must be located where visible (on the starter enclosure and/or the driven equipment) as required by local code.**

**WARNING: MOTOR CONNECTED TO THIS EQUIPMENT  
MAY START AUTOMATICALLY WITHOUT WARNING**

### NEMA Class Trip Curves

NEMA Class trip curves are based on a common tripping point of 600% of motor Full Load Amps (FLA). Curves vary by the amount of time before the unit trips. As an example, a Class 20 curve will trip in 20 seconds at 600% of FLA. The factory default setting of Class 10 will trip in 10 seconds at 600% of FLA.

### Dual Overload Trip Curves

The **VMX2 Series** Soft Starter provides two separate Overload Trip Protection Curves, one for starting and one for running conditions. The starter's At-Speed detection circuit determines when the motor has reached full speed. When the At-Speed condition is reached, the overload trip curve will shift from the Start to the Run level, as programmed in Functions F003 and F004. See Section 5.6.1 of the Advanced Installation, Operation and Programming Manual for programming details.

### Starting Overload Trip Curve

During the start mode, Overload Trip Curves are selectable from NEMA Class 5 through Class 30 only. The default setting of Class 10 allows protection for the overload capacity of the soft starter as well as the motor. Use a higher Trip Class only if nuisance tripping occurs with the default setting.

### Running Overload Curve

During the Run mode, Overload trip curves are selectable from NEMA Class 5, 10, 15, 20, 25, and 30. Program the appropriate curve according to the characteristics of your motor and load.

**Overload Trip Curve Chart**

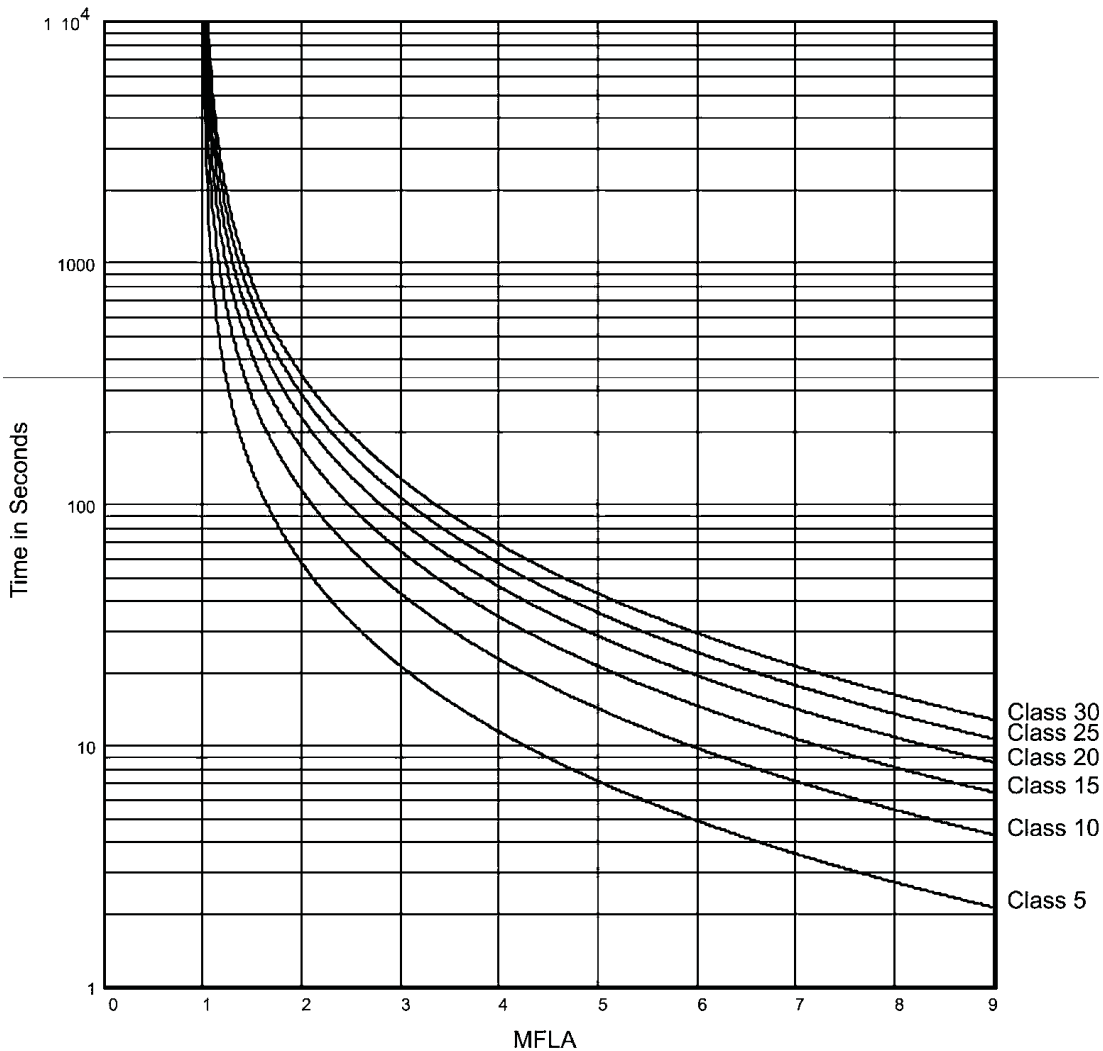

Note: Factory default setting is Class 10 for both Start and Run Overload Protection

**Figure 9: VMX2 Series Overload Trip Curves**

**Overload Protection During Bypass**

When a Bypass Contactor is used to shunt power around the SCRs in the **VMX2 Series** (as in the VMX2...-BP version), overload protection is maintained as long as the **VMX2 Series** is directly controlling the contactor. No additional Overload Relay is necessary for normal operation.

**Special Consideration for Across-the-Line (Direct-on-Line) Contactors**

When the Bypass Contactor on a **VMX2...-BP Series** has been selected to be used for Across-the-Line restart, supplemental overload protection must be added. For this application, refer to the External Overload Relay Applications supplement and wiring diagram in Appendix 5 and section 4.2.6.a of the Advanced Installation, Operation and Programming Manual for detailed instructions.



# MOTORTRONICS™

Solid State AC Motor Control

# VMX2

## Compact Soft Starter

Phasetronics, Inc. dba Motortronics  
1600 Sunshine Drive  
Clearwater, Florida 33765  
USA

Tel: + 727-573-1819 or 888-767-7792  
Fax: + 727-573-1803 or 800-548-4104

[www.motortronics.com](http://www.motortronics.com)